

MS267

Grade 6 Math Holiday Packet

March 29th-April 1st, 2024



Name: _____

Class: _____

Grade 6 Mathematics Reference Sheet

CONVERSIONS

1 inch = 2.54 centimeters

1 meter = 39.37 inches

1 mile = 5,280 feet

1 mile = 1,760 yards

1 mile = 1.609 kilometers

1 kilometer = 0.62 mile

1 pound = 16 ounces

1 pound = 0.454 kilogram

1 kilogram = 2.2 pounds

1 ton = 2,000 pounds

1 cup = 8 fluid ounces

1 pint = 2 cups

1 quart = 2 pints

1 gallon = 4 quarts

1 gallon = 3.785 liters

1 liter = 0.264 gallon

1 liter = 1,000 cubic centimeters

FORMULAS

Triangle

$$A = \frac{1}{2}bh$$

Right Rectangular Prism

$$V = Bh \text{ or } V = lwh$$

Session 1



TIPS FOR TAKING THE TEST

Here are some suggestions to help you do your best:

- Read each question carefully and think about the answer before making your choice.
- You have been provided with mathematics tools (a ruler and a protractor) and a reference sheet to use during the test. It is up to you to decide when each tool and the reference sheet will be helpful. You should use mathematics tools and the reference sheet whenever you think they will help you to answer the question.

6.EE.B.5

1 Which value of m makes the inequality true?

$$3m - 4 < 11$$

- A 4
- B 5
- C 6
- D 7

6.RP.A.3a

2 A farmer places beehives containing bees in her orchard to pollinate the plants. The table below shows the ratio of the number of beehives to the number of acres in the orchard.

BEEHIVES PER ACRE

Number of Beehives	3	9	12	18
Number of Acres	8	24	32	?

If the bees pollinate the plants at a constant rate, how many acres will be pollinated by the bees in 18 beehives?

- A 38
- B 40
- C 44
- D 48

6.G.A.4

3

The net of a rectangular prism is shown below.

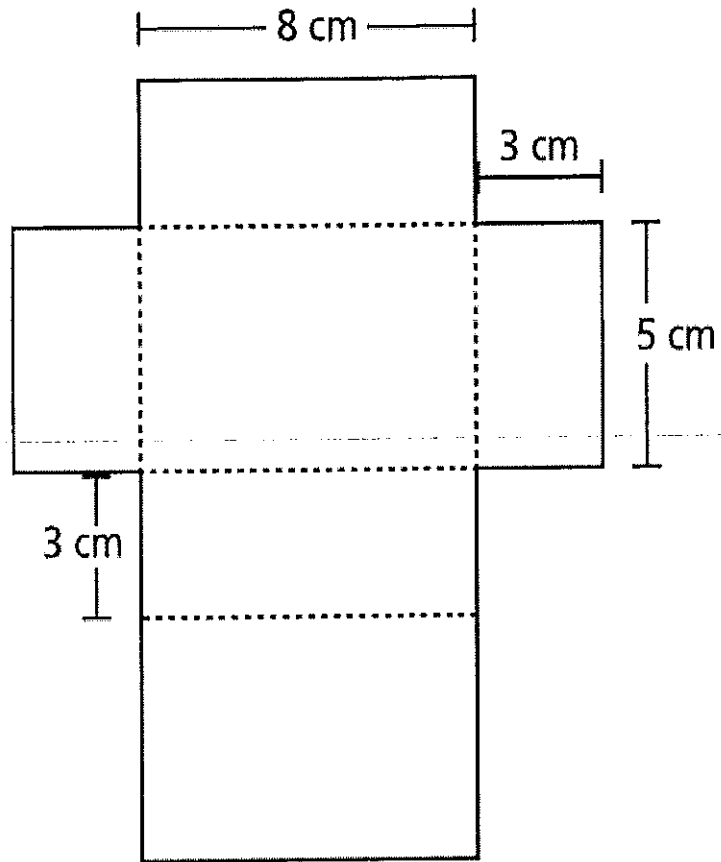

What is the surface area, in square centimeters, of the rectangular prism?

- A 60
- B 79
- C 158
- D 360

6.EE.C.9

4

Jake takes guitar lessons that cost \$120.00 per month. Which equation can be used to determine the total number of dollars, d , that Jake pays for lessons for any number of months, m ?

A $d = 120 \times m$

B $m = 120 \times d$

C $d = 120 + m$

D $m = 120 + d$

6.RP.A.1

5

Claire has 6 large envelopes and 11 small envelopes. What is the ratio of large envelopes to the total number of envelopes?

A 5 : 11

B 6 : 11

C 6 : 17

D 11 : 17

6

A bagel shop sold 8 plain bagels and 13 rye bagels. What is the ratio of the number of rye bagels to the number of plain bagels sold?

A 8 : 13

B 13 : 8

C 8 : 21

D 21 : 8

7 A rectangle is graphed on a coordinate plane. The coordinates for two of the vertices of the rectangle are $(-5, 8)$ and $(-5, -6)$. What is the distance between the two vertices?

- A 2 units
- B 4 units
- C 10 units
- D 14 units

8 What value of m makes the equation below true?

$$m + 7.9 = 39\frac{1}{2}$$

- A 5.0
- B 31.6
- C 32.4
- D 47.4

9 Point A is shown on the number line below.

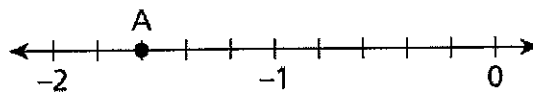

What is the location of point A?

- A -1.3
- B -1.35
- C -1.6
- D -1.75

10

A right rectangular prism has a base with an area of $25\frac{1}{2}$ square feet and a volume of 153 cubic feet. What is the height, in feet, of the right rectangular prism?

A 6

B 51

C $127\frac{1}{2}$

D $3,901\frac{1}{2}$

6.EE.A.2c

11 What is the value of the expression shown below when $x = 7$?

$$3x^2 - 2x + 3$$

- A 31
- B 50
- C 136
- D 164

6.G.A.1

12 A partially shaded rectangle is shown below.

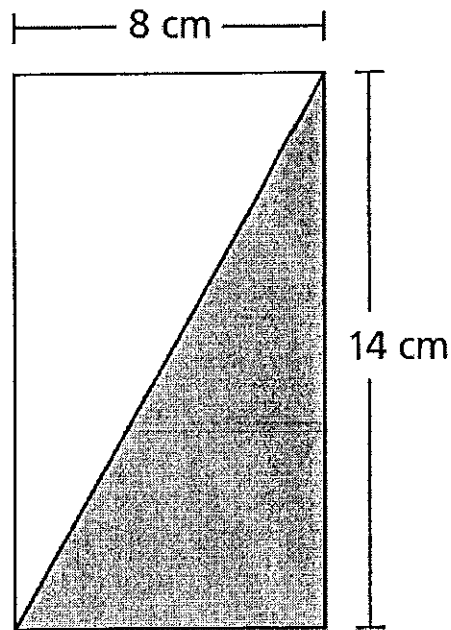

What is the area, in square centimeters, of the shaded part of the rectangle?

- A 28
- B 44
- C 56
- D 112

13

An expression is shown below.

$$\frac{143 - 35}{3^3}$$

What is the value of the expression?

A 4

B 9

C 12

D 18

14

There are 230 calories in 4 ounces of a type of ice cream. How many calories are in 6 ounces of that ice cream?

A 232

B 236

C 345

D 460

6.RP.A.3c

15 A group of 10 Science Club students is on a field trip. That number of students represents 20% of the total number of students in the Science Club. What is the total number of students in the Science Club?

- A 20
- B 30
- C 50
- D 80

6.EE.B.5

16 Which value of x makes the equation true?

$$4x - 8 = 4$$

- A 1
- B 3
- C 4
- D 9

6.RP.A.3d

17 Employees at a construction company are building a fence around the perimeter of a work site. The perimeter of the work site is $\frac{1}{4}$ mile. The cost of the fence is \$20.00 per yard.

What is the total cost of the fence needed for the perimeter of the work site?

- A \$5,000.00
- B \$8,800.00
- C \$17,600.00
- D \$26,400.00

18

Pat bounces a basketball 25 times in 30 seconds. At that rate, approximately how many times will Pat bounce the ball in 150 seconds?

A 120

B 125

C 144

D 145

19

Which expression is equivalent to $5(4x + 3) - 2x$?

A $18x + 15$

B $18x + 3$

C $7x + 8$

D $2x + 8$

20

Mark graphed points on the coordinate plane below to represent the locations of his school and a bank.

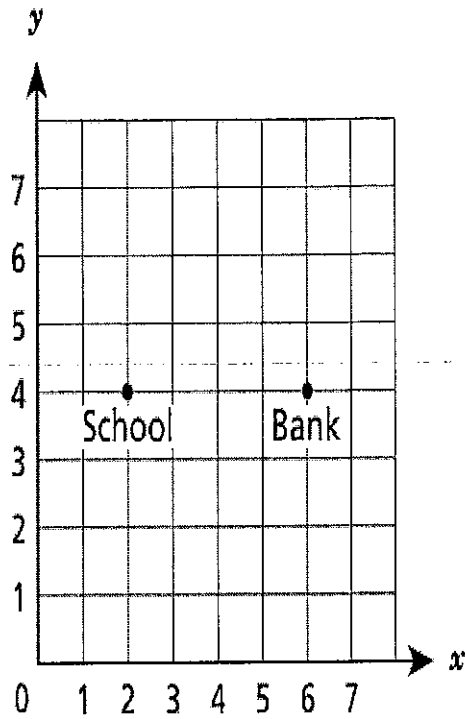

Mark wants to add the location of the library on the coordinate plane. The distance from the library to the school is the same as the distance from the bank to the school. Which ordered pair could be the coordinates of the library?

- A (2, 4)
- B (2, 8)
- C (4, 4)
- D (6, 8)

21

A student draws the net below to show the dimensions of a container that is shaped like a right rectangular prism.

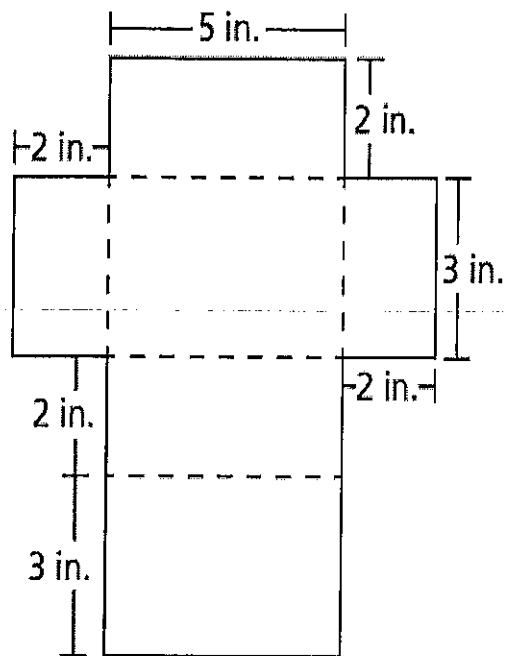

What is the surface area, in square inches, of the container?

- A 19
- B 30
- C 38
- D 62

6.NS.A.1

22 Ralph has $\frac{3}{4}$ gallon of paint. He wants to store all of the paint equally among 5 containers.

How much paint, in gallons, will Ralph store in each container?

A $\frac{3}{20}$

B $\frac{8}{5}$

C $\frac{15}{4}$

D $\frac{17}{4}$

6.G.A.1

23 A parallelogram is shown below.

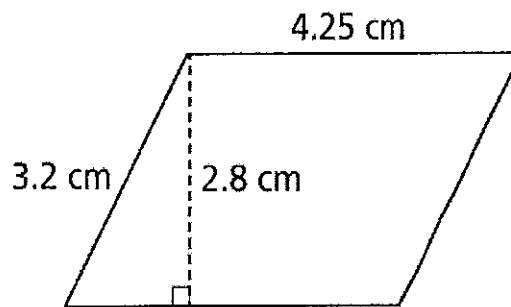

What is the area, in square centimeters, of the parallelogram?

A 8.96

B 10.25

C 11.9

D 13.6

24

Which expression represents the perimeter of the figure below?

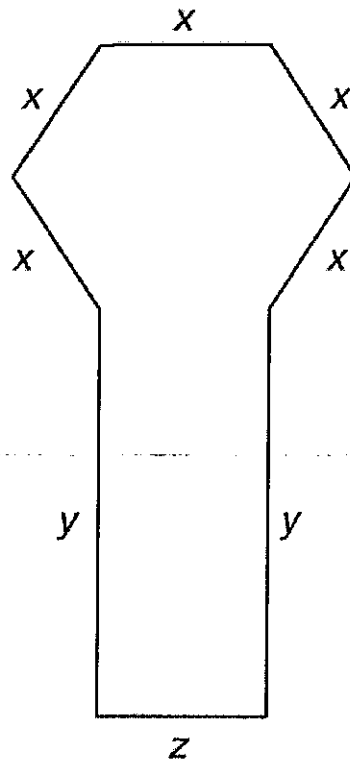

- A** $5x + 2y$
- B** $x + y + z$
- C** $5x + 2y + z$
- D** $(5 + 2 + 1)(x + y + z)$

25

Pat bounces a basketball 25 times in 30 seconds. At that rate, approximately how many times will Pat bounce the ball in 150 seconds?

A 120

B 125

C 144

D 145

6.NS.C.6c

26 A number line with points Q, R, S, and T is shown below.

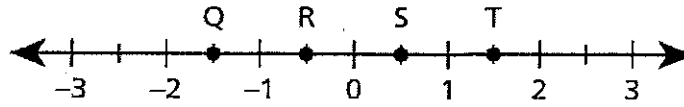

What point represents $-\frac{1}{2}$?

- A point Q
- B point R
- C point S
- D point T

6.RP.A.2

27 Ms. Wilson is buying packages of pencils. Each package costs \$11.52 and contains 96 pencils. What is the unit price of a pencil?

- A \$0.12
- B \$0.96
- C \$1.20
- D \$1.92

6.G.A.3

28 Three vertices of a rectangle are located at $(2, 4)$, $(-2, -5)$, and $(-2, 4)$ on a coordinate plane. What are the coordinates of the fourth vertex of the rectangle?

- A $(2, 5)$
- B $(2, -5)$
- C $(5, 2)$
- D $(-5, -2)$

STOP

.....